

# Modelling Flow Behavior of Gas Leakage from Buried Pipeline

Petro Ndalila, Yuxing Li, and Cuiwei Liu

**Abstract** — Risks in gas transportation are usually comprised of losses of the valuable gas, fire, explosion, and destruction to the environment. The safety of this infrastructure especially flammable gas pipelines is of great importance due to potential associated risks when leakage happens. An accurate understanding of the dispersion characteristics of the leaked gas from the underground pipe is of great importance. A gas leaking model from the buried pipeline was established based on computational fluid dynamics (CFD) technique, to simulate the situation. At the incidence of leakage, gas will propagate out and cause changes in flow behavior, which will prompt the detectors. The leakage position influences significantly much on the strength of leak signals to be detected at the ground surface. Under the simulation process, the double leakage pipeline model was involved. The variation of flow parameters inside the pipeline, outside pipeline, and the effect of leakage position were depicted and analyzed.

**Index Terms** — gas flow simulation, leakage failure, porous media.

## I. INTRODUCTION

Pipeline systems transporting petroleum products in onshore are mostly buried for safety reasons, however, they are vulnerable to the earthquake, or other natural disasters [1], [2]. Natural gas as potential clean energy, its consumption, and demand has increased nowadays among both domestic users in urban and industrial as well [3], [4]. The consumers are pipeline connected from the supplier for a continuous supply. The suitability of pipeline can sometimes have limitations and vinegar situation. Due to aging, corrosion, defects of pipes and welds, especially with the development of urban construction, accidents of digging and fracturing, which frequently lead to fire and explosion, resulting in personnel death and environmental pollution [5]. The danger of gas pipeline leakage diffusion can vary depending on different soil conditions of the buried pipeline. It is important for the pipeline facilities owner or authority to ensure the safety of the pipeline and the transported material [6].

Understanding the fluid flow behavior and transport

properties in porous media or soil are of importance for the proper detection design of leakage along the pipeline. The diffusion of fluid in the porous medium will follow the pore structure of the specific soil and not as a straight line as in the air. The particle size of soil has a great influence on soil hydraulic such as permeability, porosity, and density. The soil can be classified and measured in many different ways, depending on the relative composition of sand, silt and clay content [7]. Sand has the largest soil particle size (2.0 mm - 0.05 mm), silt is intermediate in size (0.05 mm - 0.002 mm), and clay is the smallest (less than 0.002 mm) [8]. In clay soil, because the particle size is very small, the flow resistance will usually be high not as in silt and sand. Direct numerical modeling of the effects of the pore structure of soil on the gas diffusion process is very complex. In order to investigate the transport properties and flow behavior in porous media, researchers usually use the porosity as a parameter to characterize the characteristics of flow in porous media, which greatly simplifies the complexity of the problem. The description is a prerequisite for predicting the flow behavior in porous media, while porosity and pore structure are among key parameters [9], [10]. For the influence of pore structures on the diffusion process, few studies have provided detailed, intuitive and accurate information, however, there is no in-depth report on how various geometric structures affect diffusion on behavior at the pore scale.

Reference [11], the author's developed a 2D simulation process on the migration of gaseous and dissolved CO<sub>2</sub> in the saturated porous media to figure out the sensitive parameters to detect the CO<sub>2</sub> leakage in the system. His finding was based on low and high permeability conditions, where under low permeability condition the injected CO<sub>2</sub> was blocked by layer and the gas plume was expanded laterally. Unlikely for high permeability conditions the gaseous CO<sub>2</sub> was accumulated inside the layer. However, in the early injection stage, there was no evidence of leakage into background media in both conditions. The pressure in gas accumulated zone of each condition increased gradually, exceeded the threshold of the upper medium and CO<sub>2</sub> intruded into the upper media.

Reference [12] developed a 2D and 3D model of a buried gas pipeline intentionally to make calculator equation for low and medium operating pressure pipe with a single leak hole. It was found that the 2D was not realistic as 3D model where linear, second-order, and fourth-order relation were observed between the leak amount and the three effective parameters inlet pressure, leak hole size, and the ratio of the hole size to the pipe diameters, respectively.

Reference [13] presented a diagnosis of the pressure distribution of leaking fluid from the pipeline using

---

Published on November 16, 2020.  
P. Ndalila, China University of Petroleum, China.  
(e-mail: pndalila@outlook.com)  
Y. Li, China University of Petroleum, China.  
(e-mail: yuxing\_li19@126.com)  
C. Liu, China University of Petroleum, China.  
(e-mail: chuyunlcw@163.com).

experimental and 3D model simulation. It was found that pressure changes within the pipeline during leakage are a function of leak hole position from upstream and hole size. However, the pressure drop can be more significant when the leak hole is far from the upstream.

Reference [14] evaluated a model related to gas leakage and dispersion from a buried pipeline. The results show that there were flux and concentration distribution at different points of soil near the leak vicinity. Also, it was observed that despite the lowest release of the flammable gas a perilous was very likely.

Reference [15], studied the acoustic pressure perturbation generated due to leakage in the gas pipeline using CFD simulation and experimental methods for comparison purposes. From his finding, it was observed that gas flowing through the leak orifice generates turbulence that can induce sonic sources and hence, pressure perturbation. Also, the comparison of pressure perturbation in simulation and experimental, both had similar features under different variables of operating conditions.

Reference [16], the author's investigated the preferential path of gas migration into saturated boom clay at constant flow pressure. The distribution of pressure into the porous media is controlled by local variations in permeability and water contained in the soil. It was found that the degree of gas to breakthrough the sample is controlled by the spatial structure of the soil. The smaller the pore size, the larger the breakthrough time as a consequence of soil stiffness. This will also increase the pressure outlet of gas and open up the preferential paths for gas migration [16].

Among others, as in [17], published experimental findings on the fluidization of ballotini as a substitute for sand soil around the leakage point of the water pipeline. The intention was to monitor the fluidized zone and head drop due to flow through the leakage hole. The fluidized zone grows as per flow rate increase and remains stable at an upward direction proportional to the driven flow rate. The growth of the zone size and shape was significantly different from one flow rate to another, but sensitive to the ballotini structure. The pressure drop at the leakage point was corresponding to the orifice size.

The soil structure can relatively be unchanged for a long time unless there is a presence of an external force. The gas flow through the pores of the soil under different soil structures contributes significantly to its detection, however different soil grains respond differently [18]. As can be depicted here, most researchers are investigating the leaking pipeline with a single hole. In view of the situation, this paper establishes a 3D model at transient flow to examine the propagation of gas in clay soil structure using a simulation method in computational fluid dynamics (CFD) with commercial software Fluent tool. The flow behavior in pores structure of clay soil was investigated for the aspect of gas diffusivity leaking from pipeline. This work is regarded as a study extension where a double leakage pipeline model is investigated. The schematic geometry of the pipe surrounding porous media is shown in Fig. 1.

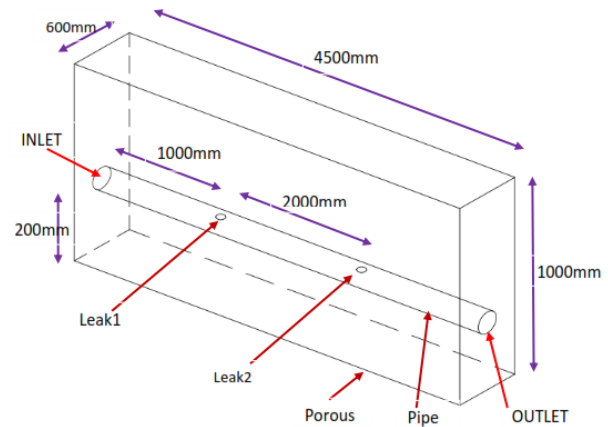

Fig. 1. Schematic diagram of buried pipe.

## II. COMPUTATIONAL MODEL

The CFD simulation can be established to predict the real situation and enhance the capture of basic information of the flow field. The simulation method as a tool to investigate the diffusion of gas from a pipe to porous has been used in different applications. In this study, a 3D model of pipe surrounding porous was employed into Fluent CFD software. The gas flowing within the pipe is compressible air. The governing equations for ideal gas flow through pipe are continuity, momentum, and energy equations which are to be solved simultaneously [19], [20];

$$\frac{\partial \rho}{\partial t} + \frac{\partial(\rho v_i)}{\partial x_i} = 0 \quad (1)$$

$$\frac{\partial(\rho v_i)}{\partial t} + \frac{\partial(\rho v_i v_j)}{\partial x_j} = -\frac{\partial p}{\partial x_i} + \frac{\partial \tau_{ij}}{\partial x_j} + \rho g + F \quad (2)$$

$$\frac{\partial(\rho E)}{\partial t} + \frac{\partial}{\partial x_i} [v_i (\rho E + p)] = \frac{\partial}{\partial x_i} \left[ k_{eff} \frac{\partial T}{\partial x_j} + v_i \tau_{eff} \right] \quad (3)$$

where  $\rho$  is the fluid density ( $\text{kg/m}^3$ ),  $v$  is the dynamic velocity (m/s),  $t$  is the time (s),  $p$  is pressure (Pa),  $\tau$  is viscous stress tensor (Pa),  $g$  is an acceleration of gravity ( $\text{m/s}^2$ ),  $F$  is external body force acting on the fluid which can be neglected for gas flow within a pipe ( $\text{N/m}^3$ ),  $E$  is total energy(J),  $k_{eff}$  is effective thermal conductivity ( $\text{W/mK}$ ) and  $T$  is the temperature (K). The term stress tensor can be calculated as follows:

$$\tau = \mu \left[ \left( \frac{\partial v_i}{\partial x_j} + \frac{\partial v_j}{\partial x_i} \right) - \frac{2}{3} \frac{\partial v_i}{\partial x_i} \right] \quad (4)$$

f

Under normal operation, the gas pipeline operates at high flow hence high Reynold number, making a turbulent flow

in a pipeline. The standard  $k-\varepsilon$  method is one of the most common turbulence models, where  $k$  is kinetic energy and  $\varepsilon$  is turbulent dissipation (the rate at which velocity fluctuations dissipate). These variables determine the scale of the turbulence and energy in the turbulence.

$$\frac{\partial}{\partial t}(\rho k) + \frac{\partial}{\partial x_i}(\rho k v_i) = \frac{\partial}{\partial x_j} \left[ \left( \mu + \frac{\mu_t}{\sigma_k} \right) \frac{\partial k}{\partial x_j} \right] + G_k + G_b - \rho \varepsilon - Y_M + S_k \quad (5)$$

$$\frac{\partial}{\partial t}(\rho \varepsilon) + \frac{\partial}{\partial x_i}(\rho \varepsilon v_i) = \frac{\partial}{\partial x_j} \left[ \left( \mu + \frac{\mu_t}{\sigma_\varepsilon} \right) \frac{\partial \varepsilon}{\partial x_j} \right] + C_{1\varepsilon} \frac{\varepsilon}{k} (G_k + C_{3\varepsilon} G_b) - \rho C_{2\varepsilon} \frac{\varepsilon^2}{k} + S_\varepsilon \quad (6)$$

where  $G_k$  is the generation of turbulence kinetic energy caused by mean velocity gradient,  $G_b$  is the generation of turbulence kinetic energy brought by buoyancy,  $Y_M$  is the contribution of the fluctuating dilatation incompressible turbulence to overall displacement rate,  $C_{1\varepsilon}$ ,  $C_{2\varepsilon}$ ,  $C_{3\varepsilon}$  and  $C_\mu$  are constants  $\sigma_k$  and  $\sigma_\varepsilon$  are the turbulent Prandtl number for  $k$  and  $\varepsilon$  respectively.  $S_k$  and  $S_\varepsilon$  are user-defined source term,  $\mu_t$  is turbulent viscosity. The turbulent viscosity and generation terms can be expressed as.

$$G_k = \mu_t \left( \frac{\partial \bar{v}_i}{\partial x_j} + \frac{\partial \bar{v}_j}{\partial x_i} \right) \frac{\partial \bar{v}_i}{\partial x_j} \quad (7)$$

$$G_b = -g_i \frac{\mu_t}{\rho Pr_t} \frac{\partial \rho}{\partial x_i} \quad (8)$$

$$Y_M = 2\rho\varepsilon \frac{k}{\gamma RT} \quad (9)$$

$$\mu_t = \rho C_\mu \frac{k^2}{\varepsilon} \quad (10)$$

where  $Pr_t$  is the turbulent Prandtl number for energy,  $\gamma$  is heat capacity ratio, and  $R$  is the gas constant (J/kgK). The model constants are given by;  $C_{1\varepsilon}=1.44$ ,  $C_{2\varepsilon}=1.92$ ,  $C_\mu=0.09$ ,  $\sigma_k = 1.0$ ,  $\sigma_\varepsilon = 1.3$  and  $Pr_t=0.85$ .

The flow-through porous media is implanted with a general equation based on pipe flow by including the porosity effect in continuity and momentum. Forchheimer equation is also adopted (into Equation 12) in order to take account non-linear results from both viscous and inert effects at the external body force term [21], [22];

$$\frac{\partial \rho}{\partial t} + \frac{\partial(\phi \rho v_i)}{\partial x_i} = 0 \quad (11)$$

$$\frac{\partial(\rho v_i)}{\partial t} + \frac{\partial(\phi \rho v_i v_j)}{\partial x_j} = -\phi \frac{\partial p}{\partial x_i} + \frac{\partial \tau_{ij}}{\partial x_j} + \phi \rho g - \left( \frac{\mu}{\alpha} + C_2 \frac{1}{2} \rho |v_i| \right) v_i \quad (12)$$

$$\frac{\partial(\rho_f E_f)}{\partial t} + \frac{\partial}{\partial x_i} [v_i(\rho_f E_f + p)] = \frac{\partial}{\partial x_i} \left[ k_{eff} \frac{\partial T}{\partial x_j} + v_i \tau_{eff} \right] \quad (13)$$

where  $\phi$  is the porosity,  $\alpha$  is permeability,  $\rho_f$  the density of fluid passing in porous,  $E_f$  energy of fluid passing in porous,  $C_2$  the inertial resistance coefficient depending on the porous particle diameter  $d_p$ . The description for permeability and inert resistance is as follows:

$$\alpha = \frac{d_p^2}{150} \frac{\phi^3}{(1-\phi)^2} \quad (14)$$

$$C_2 = \frac{3.5(1-\phi)}{d_p \phi^3} \quad (15)$$

### III. ESTABLISHMENT OF SIMULATION

The simulation was based on the 3D model of a buried pipe. The model geometry with a pipe of 42mm diameter surrounding a porous media measuring 4500x600x1000 mm was created in CAD software and imported to Fluent. Model geometry has 10 mm diameter orifices located on top of the pipe at 1000 mm and 3000 mm from upstream. The ideal gas injected through a pipe and leak at the orifice will have turbulence flow, causes the hydraulic flow parameter to be unstable. The computational meshes were generated with tetrahedral elements for both pipes, surrounding porous and fluid volume to ensure an accurate definition of flow behavior. The boundary surface (pipe inlet, pipe outlet, leak1, leak2, pipe wall surface, and ground surface as porous) was added to achieve a fully developed flow during the simulation.

In solving the flow field equations, a numerical model was performed with Fluent using the SIMPLE algorithm method. The boundary inlet condition of 4.6m/s, outlet above ground was taken the same with atmospheric gauge pressure 0Pa and outlet pressure at downstream 0.1kpa. The second-order discretization scheme was used for flow variables, turbulent kinetic energy, and turbulent dissipation rate. A reduction in the maximum residuals of 5 orders magnitude was used as the global convergence criterion for all simulations. The soil grain has 0.001mm particle size, 0.4 porosity [23], [24].

#### IV. RESULTS AND DISCUSSIONS

##### A. Pressure and Flow Behavior

The gas flow within a pipe segment has significant pressure change as it flows from left/upstream to right/downstream, however, in actual sense, it does decline with a very small magnitude as it flows to downstream as shown in Fig. 2. At each leakage vicinity, the pressure does decrease drastically, however, at the downstream leak point there is more decrease. This is due to resistance within the soil or porous, and the magnitude at leak point two is very low because it has been leaking from point one. Into the soil, the pressure magnitude is the same all over except near leakage point one because the escaping flow from the pipe it still has high-pressure magnitude than leak point two.

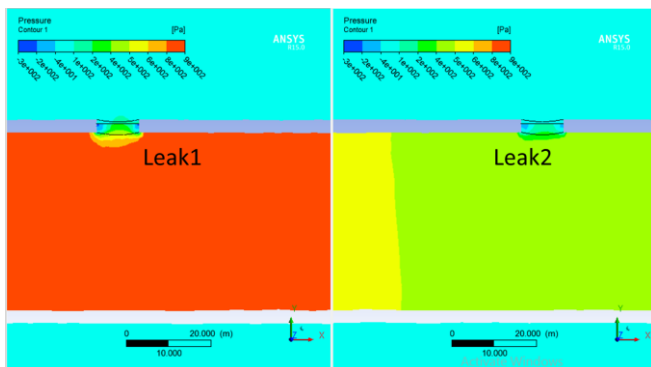

Fig. 2. Flow contour of pressure field at the leakage vicinity.

Fig. 3 shows the average trend of the pressure of the fluid domain inside the pipeline. The pressure drop between upstream and leak1 has a small degree of degradation. At each vicinity of leakage points, there is sudden great reduction and recovery, this indicates that steady-state pressure at the leak vicinity deviates greatly with magnitudes detectable by a pressure sensor. A steep pressure drop is exhibited in between leak1 and leak2, however from leak2 to downstream is slightly higher than others. Therefore, leakage orifice has more influence to provoke pressure variations caused by the leak.

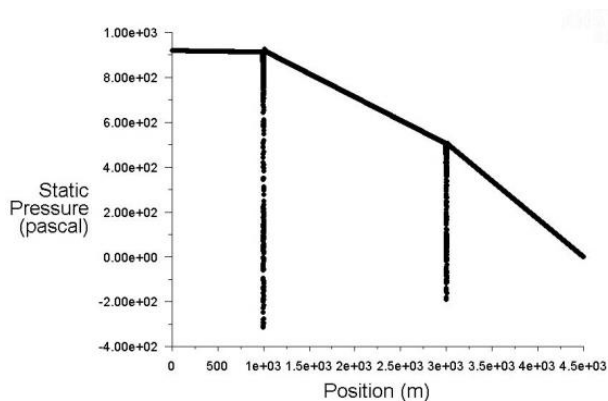

Fig. 3. The trend of pressure profile within a pipeline.

##### B. Velocity and Flow Behavior

The velocity profile of gas flow within a pipe segment has no significant change as it flows to downstream, it rather decreases slightly from one segment to another or from inlet-leak1-leak2 to outlet as shown in Fig. 4. At each

leakage vicinity, the velocity does increase drastically from pipe diffusing to the soil, at first leak point the dispersion is higher than at the downstream point. Also, at all central points of the interface between the fluid domain into a pipe and porous outside pipe the velocity has the highest magnitude of flow or choking flow.

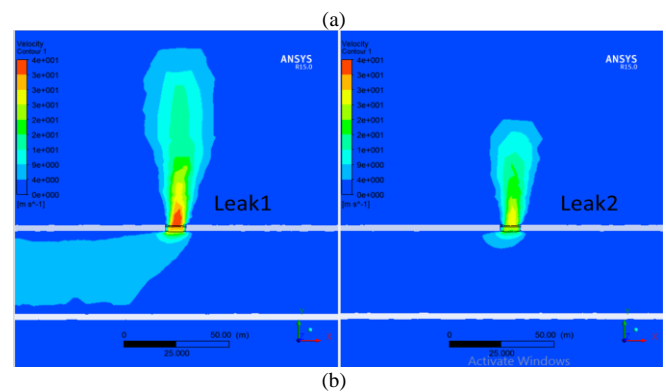
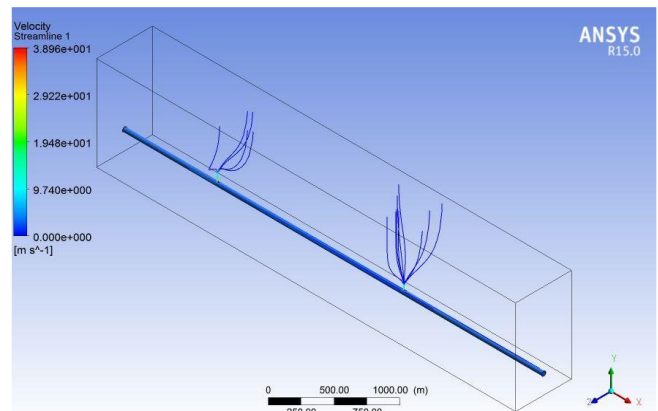

Fig. 4. Flow velocity (a) streamlines and (b) contour.

##### C. Effect of Flow Variation in Leakage Propagation

The dispersion of gas from a pipe to the soil does not march due to pores space differences from one soil texture to another. Soil with large grain size predominates pores because smaller particles do not fill the spaces between. The flow propagation of gas in clay soil is much slower due to its relatively small pores. As the grain size becomes smaller, total pore spaces for gas to flow become limited. This is turn influences pore space distribution. The flow resistance of the air in clay at upstream is not as higher as at downstream, because the pressure at upstream is much higher than downstream. As the flow rate increases inside a pipe, the same with dispersion at the leakage point increases too. Also, the magnitude difference between leak points slightly increases as presented in Fig. 5.



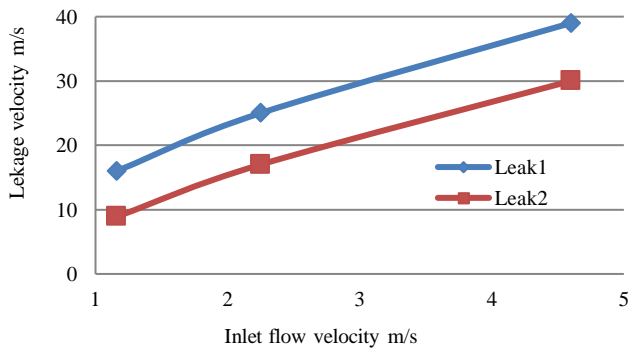

Fig. 5. The trend of leaking velocity in relation to the inlet.

## V. CONCLUSION

A model predicting the flow behavior of air into porous media for the different flow of double leakage pipeline has been presented. The proposed 3D pipeline structure was modeled, where its system of equations of the conservation laws and standard  $k-\epsilon$  were solved with Fluent software. The proposed model showed that the structure guarantees a feasible situation. Such a robust double leak detection simulation approach will provide an important relative additional advantage for visualizing related situation at a wide range. However, most of the leak detection and localization studies are interest in the case of single leaks, and the double leak localization method has not been studied widely. Based on simulation results and discussion, the following conclusion may be outlined:

- i. The presence of leakage along the pipe affects the attenuation pressure and development of the disturbing signal irrespective of the axial position of the leakage point. This shows how effective signal is dictated as leakage alive.
- ii. Also, the same with velocity flow behavior is shown to be successful in detecting the leakage presence along the pipe.
- iii. The aspect ratio of pipe, leakage position and magnitude of diffusing flow from it affect the distribution of dispersing velocity.

## ACKNOWLEDGMENT

This work was supported by the National Natural Science Foundation of China [grant numbers 51704317, 51774313]; the Shandong Provincial Key R&D Program (2020GSF111026); the PetroChina Innovation Foundation [grant number 2018D-5007-0603]; the Fundamental Research Funds for the Central Universities [grant numbers 19CX07004A]. We are grateful for permission to publish this stud.

## REFERENCES

- [1] A. G. Psyrras, N. K., & Sextos, "Safety of buried steel natural gas pipelines under earthquake-induced ground shaking: A review," *Soil Dyn. Earthq. Eng.*, pp. 254–277, 2018.
- [2] C. Zhang, L. Liu, X. Liao, X. Hu, F. Zhihong, and B. Li, "ANSYS Simulation Model of Buried Metal Pipeline Corrosion Detection," in *IOP Conf. Series: Earth and Environmental Science*, 2020.
- [3] C. Liu, Y. Li, L. Fang, and M. Xu, "New leak-localization approaches for gas pipelines using acoustic waves," *Measurement*, 2018.
- [4] R. S. Kangyin Dong, Xiucheng Dong, "How did the price and

- income elasticities of natural gas demand in China evolve from 1999 to 2015? The role of natural gas price reform," *Pet. Sci.*, pp. 685–700, 2019.
- [5] D. Ben-Mansour, R., Habib, M. A., Khalifa, A., Youcef-Toumi, K., & Chatzigeorgiou, "Computational fluid dynamic simulation of small leaks in water pipelines for direct leak pressure transduction," *Comput. Fluids*, pp. 110–123, 2012.
- [6] D. Shantanu and S. Sarkar, "A review on different pipeline fault detection methods," *J. Loss Prev. Process Ind.*, vol. 41, pp. 97–106, 2016.
- [7] Y. Jifeng, D., Chengzhong, M., and Hongzhou, "Different Soil Particle-Size Classification Systems for Calculating Volume Fractal Dimension—A Case Study of *Pinus sylvestris* var *Mongolica* in Mu Us Sandy Land, China," *Appl. Sci.*, p. 1872, 2018.
- [8] J. Y. Yang, X. M., Drury, C. F., Reynolds, W. D. & Yang, "How do changes in bulk soil organic carbon content affect carbon concentrations in individual soil particle fractions?," *Scientific 6:27173*. <https://www.nature.com/articles/srep27173.pdf>, 2016. .
- [9] W. Liu, Z. Zhang, J. Fan, D. Jiang, Z. Li, and J. Chen, "Research on gas leakage and collapse in the cavern roof of underground natural gas storage in thinly bedded salt rocks," *J. Energy Storage*, vol. 31, no. 101669, 2020.
- [10] Z. Zhou, J. Zhang, X. Huang, J. Zhang, and X. Guo, "Trend of soil temperature during pipeline leakage of high-pressure natural gas: Experimental and numerical study," *Measurement*, vol. 153, no. 107440, 2020.
- [11] K.-K. L. Seung-Wook Ha, Byeong-Hak Park, Seung Hyun Lee, "Experimental and numerical study on gaseous CO2 leakage through shallow-depth layered porous medium: implication for leakage detection monitoring," in *Energy Procedia*, 2017, pp. 3033 – 3039.
- [12] A. Ebrahimi-Moghadam, M. Farzaneh-Gord, A. Arabkoohsar, and A. Moghadam, "CFD analysis of natural gas emission from damaged pipelines: Correlation development for leakage estimation," *J. Clean. Prod.*, vol. 199, pp. 257–271, 2018.
- [13] H. Fu, L. Yang, H. Liang, S. Wang, and K. Ling, "Diagnosis of the single leakage in the fluid pipeline through experimental study and CFD simulation," *J. Pet. Sci. Eng.*, no. 107437, 2020.
- [14] M. Parvini and E. Gharagouzlou, "Gas leakage consequence modeling for buried gas pipelines," *J. Loss Prev. Process Ind.*, vol. 37, p. 110e118, 2015.
- [15] C. Liu, Y. Li, L. Meng, W. Wang, F. Zhao, and J. Fu, "Computational fluid dynamic simulation of pressure perturbations generation for gas pipelines leakage," *Comput. Fluids*, vol. 119, pp. 213–223, 2015.
- [16] E. E. Delahaye, C. H., & Alonso, "Soil heterogeneity and preferential paths for gas migration," *Eng. Geol.*, pp. 251–271, 2002.
- [17] A. Van Zyl, J. E., Alsaydalani, M. O. A., Clayton, C. R. I., Bird, T., & Dennis, "Soil fluidisation outside leaks in water distribution pipes – preliminary observations," *Proc. Inst. Civ. Eng. - Water Manag.*, pp. 546–555, 2013.
- [18] L. A. Ismail, M. I. M., Dziyauddin, R. A., Salleh, N. A. A., Muhammad-Sukki, F., Bani, N. A., Izhar, M. A.M., & Latiff, "A Review of Vibration Detection Methods Using Accelerometer Sensors for Water Pipeline Leakage," *IEEE Access*, p. 1, 2019.
- [19] S. Yigang, L. and Haiou, "Experimental and Numerical Study on the Resistance Performance of an Axial Flow Cyclone Separator," *Math. Probl. Eng.*, pp. 1–9, 2015.
- [20] M. Agegnehu, A., Tilahun, "Modeling and Simulation of Real Gas Flow in a Pipeline," *J. Appl. Math. Phys.*, pp. 1652–1681, 2016.
- [21] M. Ebrahimi-Moghadam, A., Farzaneh-Gord, M., & Deymi-Dashtebayaz, "Correlations for estimating natural gas leakage from above-ground and buried urban distribution pipelines," *J. Nat. Gas Sci. Eng.*, pp. 185–196, 2016.
- [22] S. L. Ewing, R. E., Wang, J., & Weekes, "On the simulation of multicomponent gas flow in porous media," *Appl. Numer. Math.*, pp. 405–427, 1999.
- [23] J. Collins, R., and Boxall, "Influence of ground conditions on intrusion flows through apertures in distribution pipes," *J. Hydraul. Eng.*, pp. 1052–1061, 2013.
- [24] A. I. Martin, "Hydrate Bearing Sediments - Thermal Conductivity, MSc. Thesis," Georgia Institute of Technology, 2004.



**Petro Ndalila** is a teacher at the department of chemical processing and environmental engineering at Mbeya University of Science and Technology College of engineering technology. He is also a PhD candidate at China University of Petroleum (East China), where he furthers his research on oil and gas pipeline transportation engineering technology.



**Yuxing Li** is academician and Professor of oil and gas storage and transportation engineering field at China University of Petroleum (East China). Prof. Li is a Dean, School of Storage, Transportation and Civil Engineering, at China University of Petroleum (East China). Reviewer of important academic journals at home and abroad. An expert on the National Natural Science Foundation of China, an expert on the evaluation of the National Science and Technology Awards. Director of the National Virtual

Teaching Simulation Experiment Center of Oil and Gas Storage and Transportation Engineering, Director of Shandong Provincial Key Laboratory of Oil and Gas Storage and Transportation Safety, Director of Qingdao Huanhai Oil and Gas Storage and Transportation Key Laboratory, Director of CNPC Liquefied Natural Gas and Heavy Gas Storage and Transportation Technology Laboratory.

His research interest is on the "innovative oil and gas engineering theory and technology" of the school's disciplinary innovation platform, the "high-pressure gas pipeline sound wave leak detection experimental device". After years of research, he has accumulated many scientific and technological achievements which have been promoted and applied at home and abroad. He has won 20 provincial and ministerial awards and 17 bureau-level awards. Also, he have obtained more than 30 national patents; 10 software copyright registrations, published more than 360 academic papers, and included more than 160 papers in SCI and EI.

Prof. Li is a member of the Ninth Committee of China Petroleum Institute of Natural Gas, member of China Petroleum Institute of Oil and Gas Storage and Transportation Committee, member of LNG Committee of China Gas Association, and vice chairman of ASME PSD China Branch. Member of the Professional Standardization Committee for Oil and Gas Storage and Transportation, Member of the Liquefied Natural Gas Standard Committee of the National Petroleum and Natural Gas Standardization Technical Committee, Member of the Academic Committee of the National Energy Deepwater Oil and Gas Engineering Technology Research and Development Center, and Member of the National Security Agency's safety evaluation expert database and a member of the CCUS roadmap compilation team for national carbon dioxide emissions reduction.



**Cuiwei Liu** is academician and Associate Professor of oil and gas storage and transportation engineering at China University of Petroleum (East China).

His research interest is on Long-distance oil and gas pipeline transportation technology; leakage monitoring technology for oil, gas and water pipelines; pipeline sound field and vibration analysis; consequences and disaster analysis of oil and gas pipelines and facilities; human factor analysis; bubble dynamics. Over the years, he has published more than 30 papers, many of which are included in SCI and EI. Also, he has made remarkable achievements and rewards at provincial and ministerial level such as "the key technology and application of carbon dioxide transportation and oil displacement production fluid gathering and transportation" and "Acoustic-based leak detection and location technology for gas pipelines".